

Features

- ◆ 500V, 3A, $R_{DS(ON)}(Typ.) = 3.4\Omega @ V_{GS} = 10V$.
- ◆ Low C_{rss}
- ◆ Fast Switching
- ◆ 100% Avalanche Tested

Application

- ◆ Adaptor
- ◆ Standby Power
- ◆ Switching power supply
- ◆ LED Power

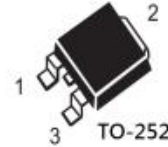
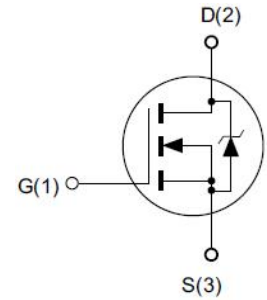

Absolute Maximum Ratings $T_c = 25^\circ C$ unless otherwise noted

Symbol	Parameter	Rating	Unit
V_{DS}	Drain-Source Voltage ^a	500	V
V_{GS}	Gate-Source Voltage	± 30	V
I_D	Drain Current-Continuous, $T_C = 25^\circ C$	3	A
	Drain Current-Continuous, $T_C = 100^\circ C$	1.8	A
I_{DM}	Drain Current-Pulsed ^b	12	A
P_D	Maximum Power Dissipation @ $T_J = 25^\circ C$	39	W
dv/dt	Peak Diode Recovery dv/dt ^c	5	V/ns
E_{AS}	Single Pulsed Avalanche Energy ^d	80	mJ
T_J, T_{STG}	Operating and Store Temperature Range	150, -55 to 150	$^\circ C$

Thermal Characteristics

Symbol	Parameter	Value	Unit
$R_{\theta JC}$	Thermal Resistance, Junction to Case	3.2	$^\circ C/W$
$R_{\theta JA}$	Thermal Resistance, Junction to Ambient	62.5	$^\circ C/W$

Electrical Characteristics $T_J = 25^\circ C$ unless otherwise noted

■ Off Characteristics

Symbol	Parameter	Test Condition	Min.	Typ.	Max.	Unit
BV_{DSS}	Drain-Source Breakdown Voltage	$V_{GS} = 0V, I_D = 250\mu A$	500	-	-	V
I_{DSS}	Zero Gate Voltage Drain Current	$V_{DS} = 500V, V_{GS} = 0V$	-	-	1	μA
I_{GSS}	Forward Gate Body Leakage Current	$V_{DS} = 0V, V_{GS} = \pm 30V$	-	-	± 100	nA



MPD05N50D

N-Channel Power MOSFET

■ On Characteristics

Symbol	Parameter	Test Condition	Min.	Typ.	Max.	Unit
$V_{GS(th)}$	Gate Threshold Voltage	$V_{DS} = V_{GS}, I_D = 250\mu A$	2.0	-	4.0	V
$R_{DS(on)}$	Static Drain-Source On-Resistance	$V_{GS} = 10V, I_D = 1.5A$	-	3.4	3.8	Ω
g_{fs}	Forward Transconductance	$V_{DS}=15V, I_D=1.5A$	-	2.5	-	S

■ Dynamic Characteristics

Symbol	Parameter	Test Condition	Min.	Typ.	Max.	Unit
R_g	Gate Resistance	$f = 1.0MHz$	-	2.7	-	Ω
C_{iss}	Input Capacitance	$V_{DS} = 25V,$ $V_{GS} = 0V,$ $f = 1.0MHz$	-	196	-	pF
C_{oss}	Output Capacitance		-	32.5	-	pF
C_{rss}	Reverse Transfer Capacitance		-	4.5	-	pF

■ On Characteristics

Symbol	Parameter	Test Condition	Min.	Typ.	Max.	Unit
$t_{d(on)}$	Turn-On Delay Time	$V_{DD} = 250V, I_D = 3A,$ $V_{GS}=10V, R_g=25\Omega$	-	8	-	ns
t_r	Turn-On Rise Time		-	11	-	ns
$t_{d(off)}$	Turn-Off Delay Time		-	31	-	ns
t_f	Turn-Off Fall Time		-	17	-	ns
Q_g	Total Gate Charge	$V_{DS} = 400V, I_D = 3A,$ $V_{GS} = 10V$	-	10.1	-	nC
Q_{gs}	Gate-Source Charge		-	3.5	-	nC
Q_{gd}	Gate-Drain Charge		-	4.9	-	nC

■ Drain-Source Diode Characteristics

Symbol	Parameter	Test Condition	Min.	Typ.	Max.	Unit
I_S	Drain-Source Diode Forward Continuous Current	$V_{GS} = 0V$	-	-	3	A
I_{SM}	Maximum Pulsed Current	$V_{GS} = 0V$	-	-	12	A
V_{SD}	Drain-Source Diode Forward Voltage	$V_{GS} = 0V, I_S = 3A$	-	0.85	1.2	V
T_{rr}	Body Diode Reverse Recovery Time	$I_S=3A, V_{GS} = 0V$ $dI_F/dt=100A/us$	-	135	-	ns
Q_{rr}	Body Diode Reverse Recovery Charge		-	400	-	nC

Notes:

- $T_J = +25^\circ C$ to $+150^\circ C$
- Repetitive rating; pulse width limited by maximum junction temperature.
- $I_{SD} = 5A, dI_F/dt \leq 100A/us, V_{DD} \leq BV_{DS},$ Start $T_J = 25^\circ C$.
- $L = 10mH, V_{DD} = 50V, I_{AS} = 4A, R_G = 25\Omega$ Starting $T_J = 25^\circ C$.

Characteristic Curve

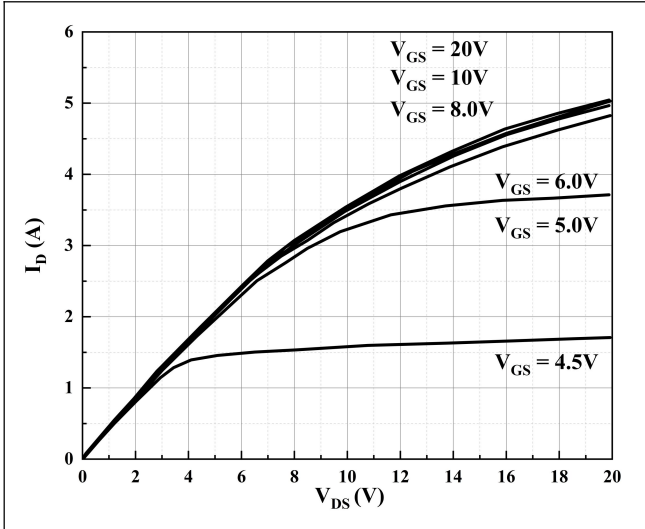

Figure 1. Typical Output Characteristics

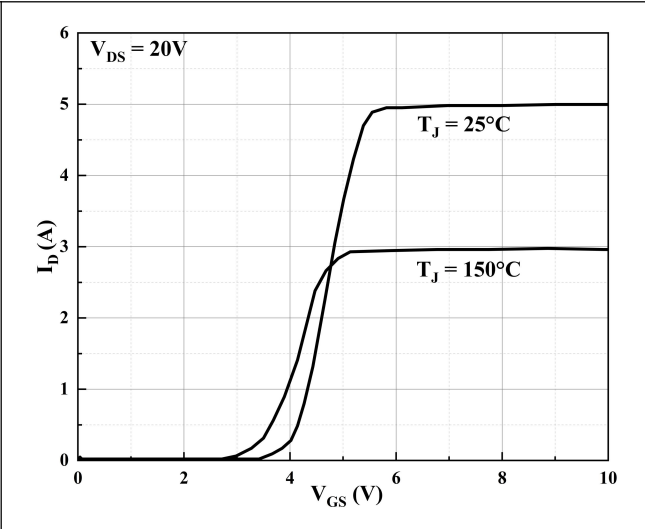

Figure 2. Typical Transfer Characteristics

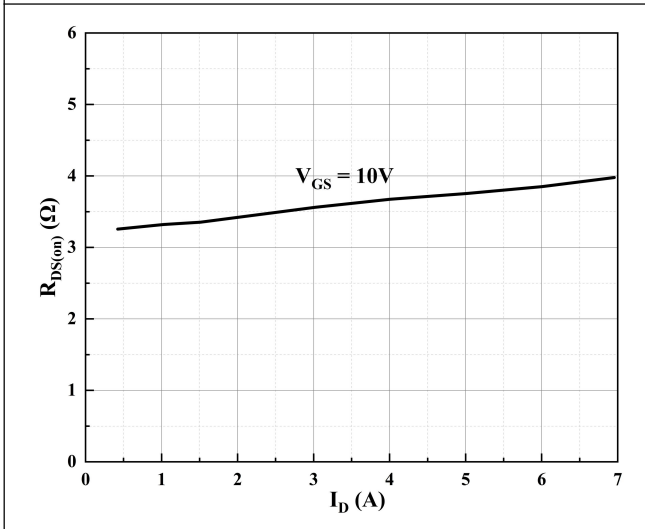

Figure 3. On-Resistance vs. Drain Current

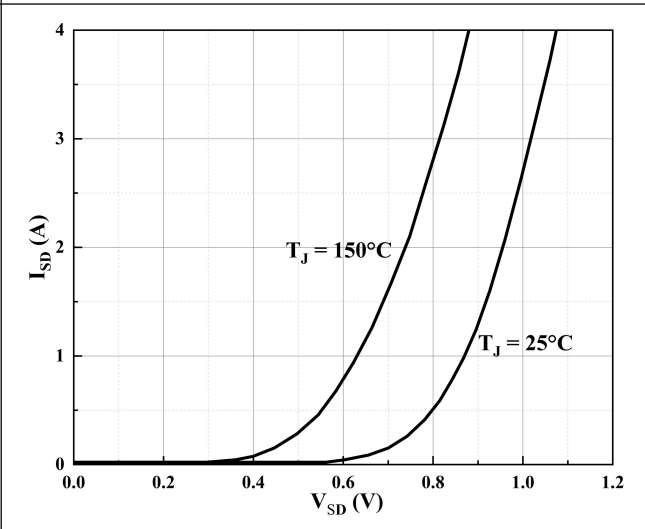

Figure 4. Body-Diode Characteristics

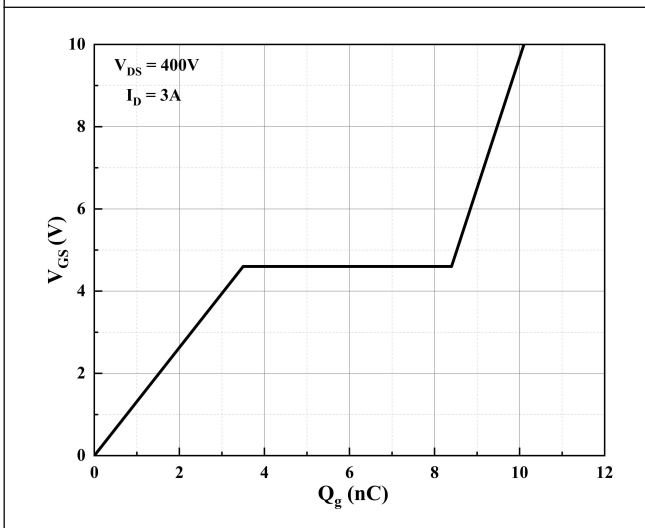

Figure 5. Gate-Charge Characteristics

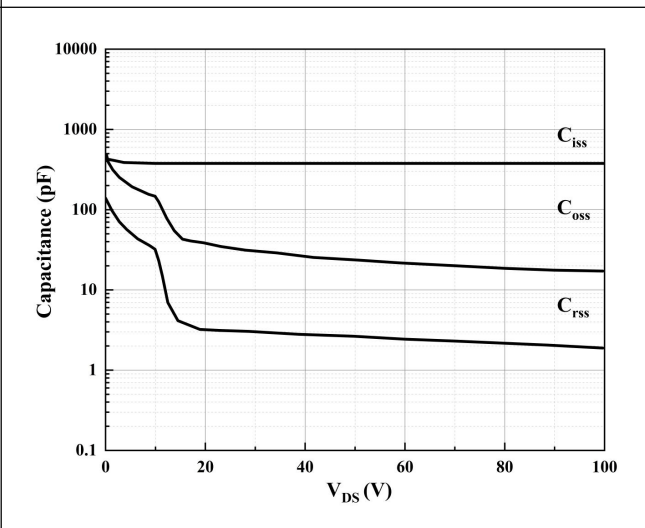

Figure 6. Capacitance Characteristics

Characteristic Curve

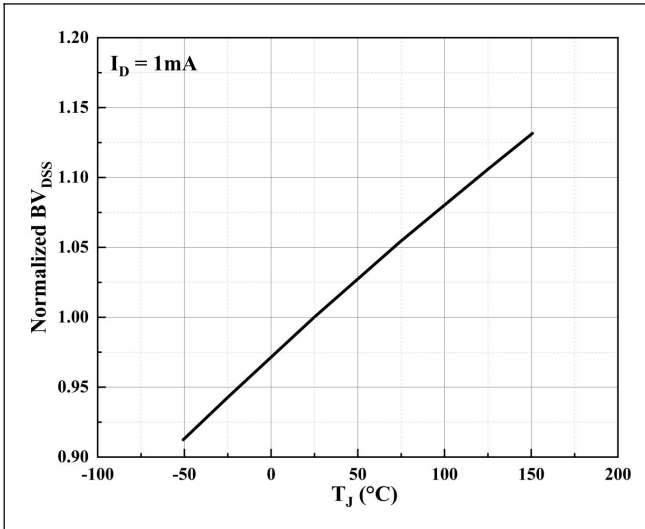

Figure 7. Normalized Breakdown voltage vs. Junction Temperature

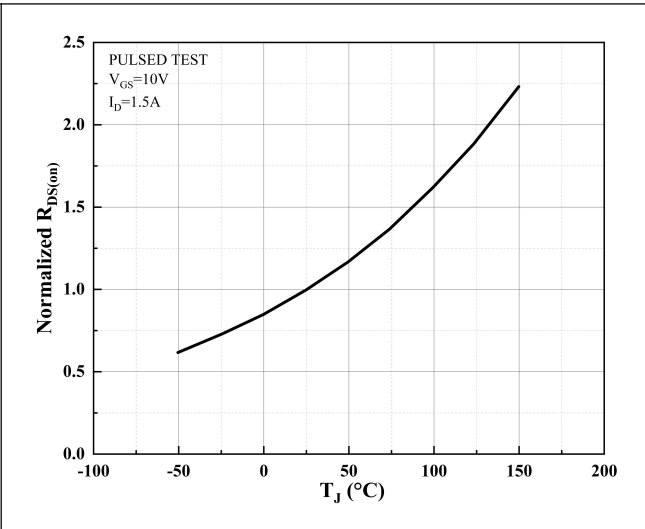

Figure 8. Normalized on Resistance vs. Junction Temperature

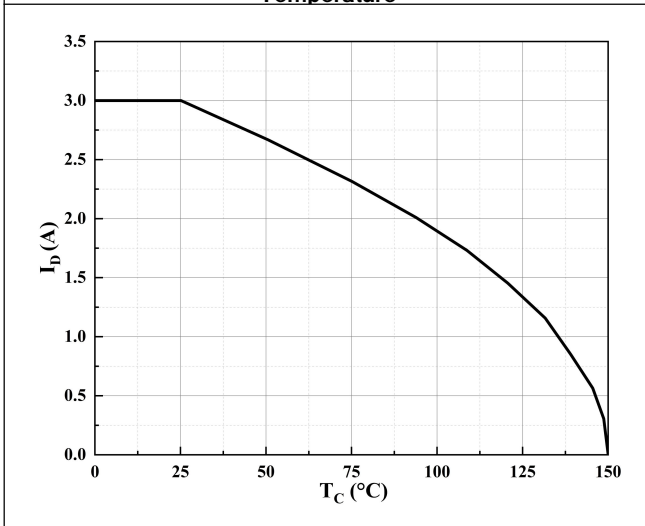

Figure 9: Maximum Continuous Drain Current vs. Case Temperature

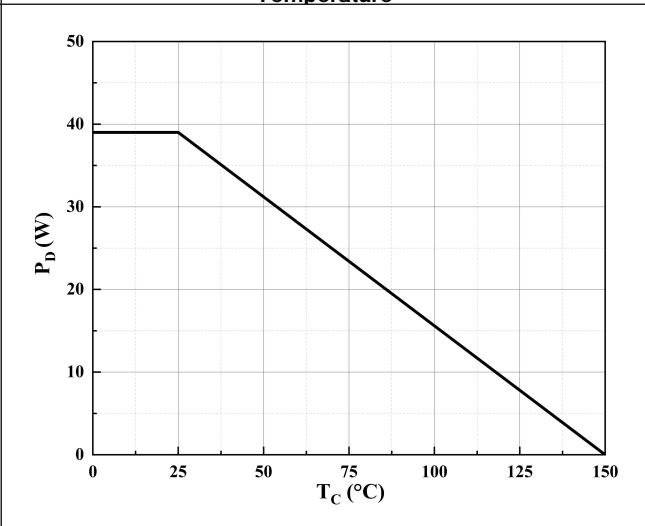

Figure 10: Maximum Power Dissipation vs Case Temperature

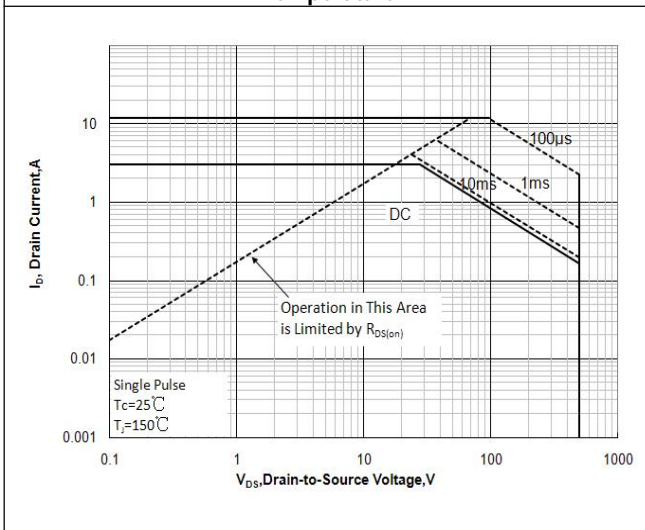

Figure 11. Maximum Safe Operating Area

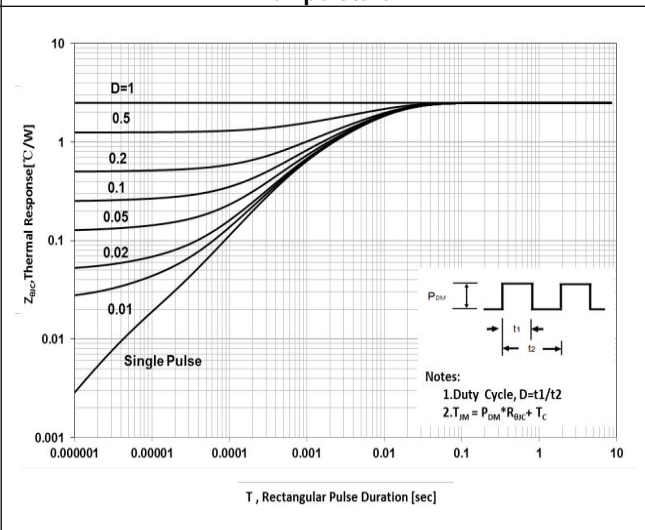
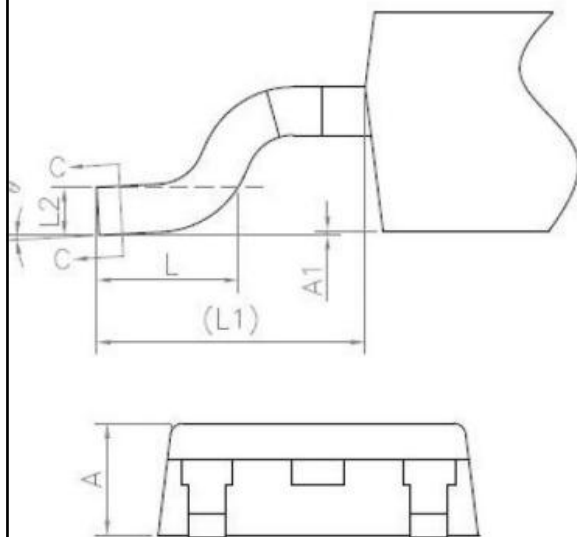
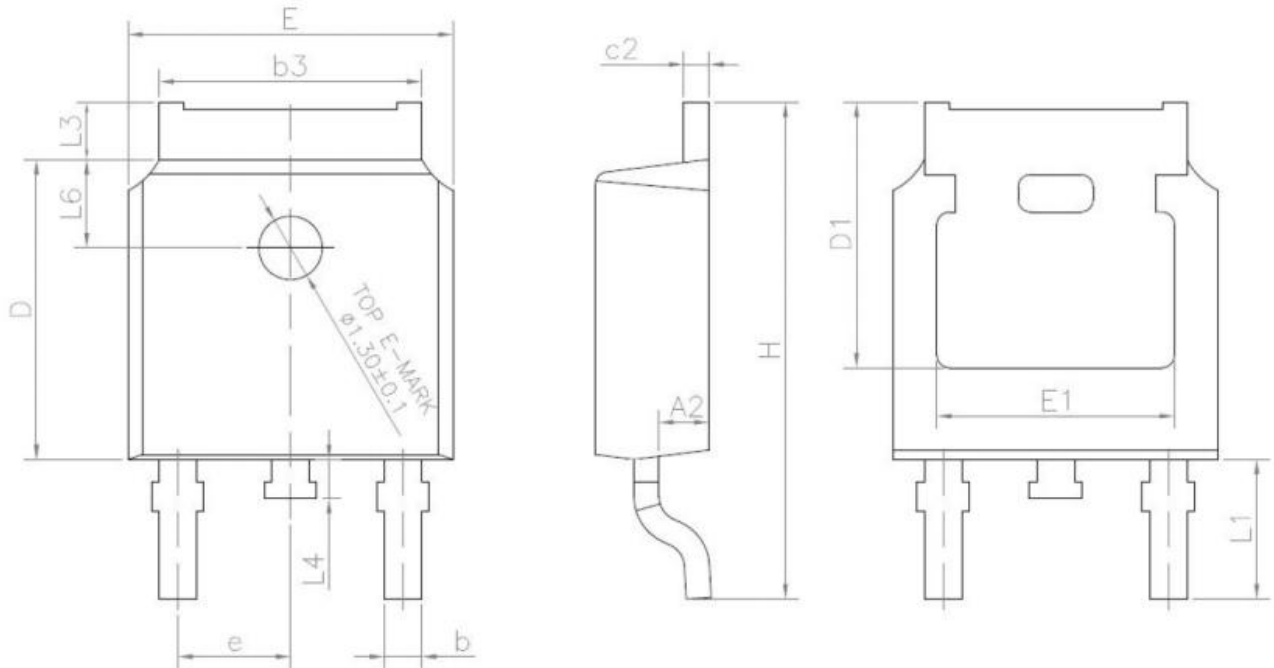

Figure 12: Normalized Maximum Transient Thermal Impedance

■ Package Information

Outlines TO-252 Package



SYMBOL	MIN	NOM	MAX
A	2.2	2.3	2.4
A1	0	--	0.2
A2	0.9	1.035	1.17
b	0.645	--	0.9
b3	5.13	5.326	5.46
c	0.43	--	0.61
c2	0.41	--	0.61
D	5.98	6.1	6.22
D1	5.244	--	--
E	6.4	6.6	6.73
E1	4.63	--	--
e	2.186	2.286	2.386
H	9.4	10.04	10.5
L	1.38	1.5	1.75
L1	2.6	2.872	3
L2	0.5	0.509	0.52
L3	0.88	--	1.28
L4	0.5	--	1
L6	1.5	1.7	1.95
θ	0°	--	10°